

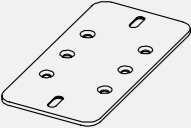



# CITTÀ

## Tatamu Dining Table

### Installation & Assembly Instructions

Rail Bracket x 1	Rail Bracket 2 x 1	Leg Bracket x 4	Down Bolts x 22	Up Bolts x 14
				
Legs x 4	Rail x 1	Top x 1		
				

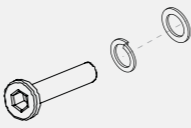
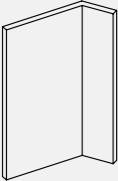
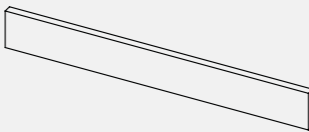
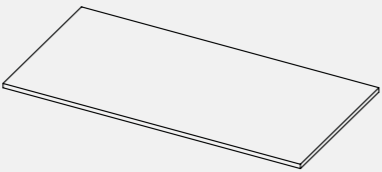
### Step 1

Using the countersunk down bolts and hex key provided, fix the rail brackets to the rail.

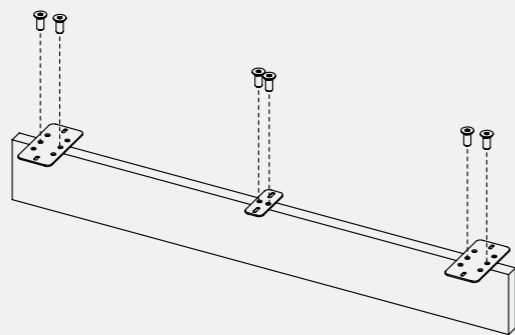

### Step 2

Stand the legs in place and slot the rail into the four legs.

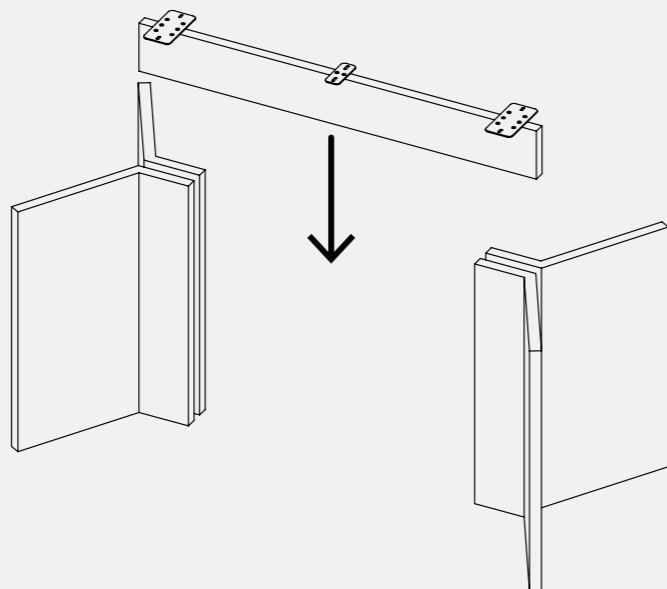

2

### Step 3

Fix the leg brackets in place with the remaining down bolts.

Note: there are left and right leg brackets, the slotted bolt holes should point to the center of the table.

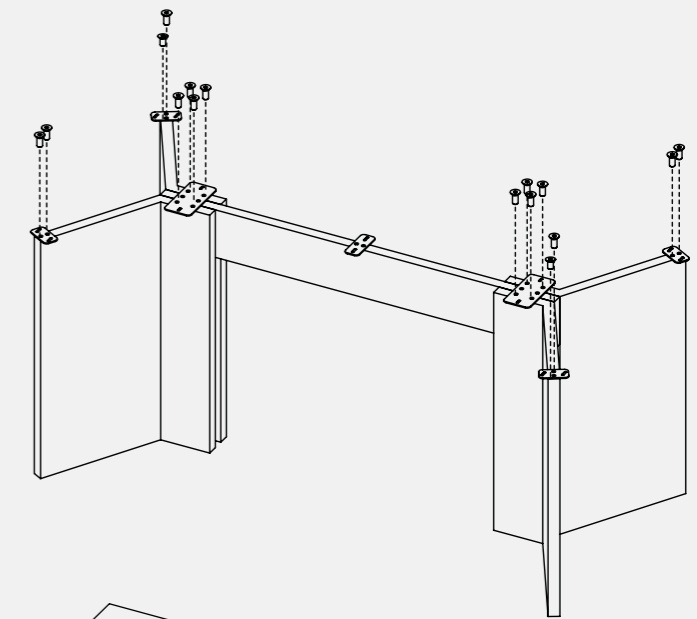

### Step 4

Locate the table top onto the frame. Making sure that the brackets are slotted into the recessed notches on the table top.

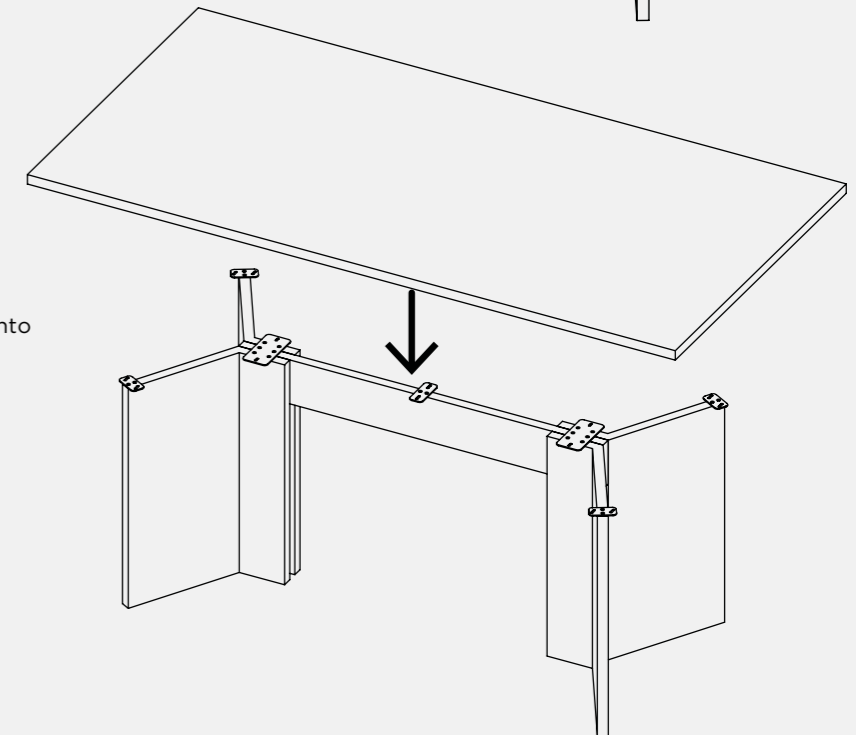

### Step 5

Secure the table top onto the frame using the up bolts, washer and spring washers.

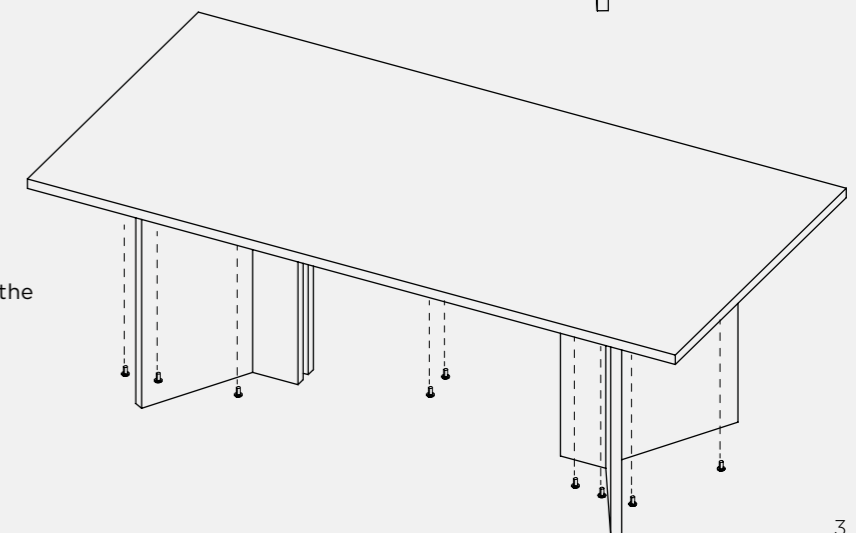

3

CITTÀ