

ELEVATION DINING TABLE

CITTÀ

Assembly Instructions

Legs x 4	Table Top x 1	Bolts x 16
		

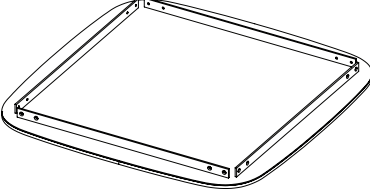
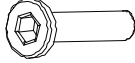
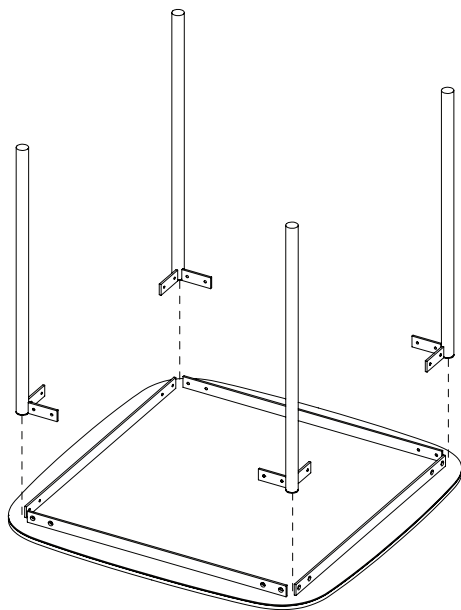

1.

Place tabletop upside down on a clean soft surface. Locate the legs onto the tabletop, with the leg brackets to the inside of the tabletop rails.

2.

Using the hex key provided; tighten each bolt through the tabletop rail into the leg bracket. Once the legs are secured, use two people to flip the table into the upright position.

