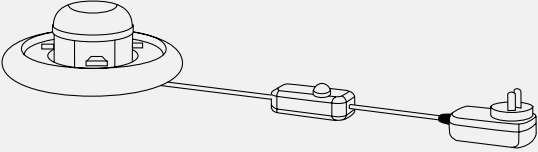
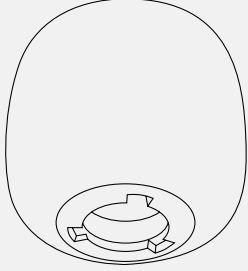

# CITTÀ

## AB Table Lamp

Marble Base x 1	Glass Shade x 1
	

### Step 1

Align the gaps at the bottom of the glass lampshade to the blades of the LED module;

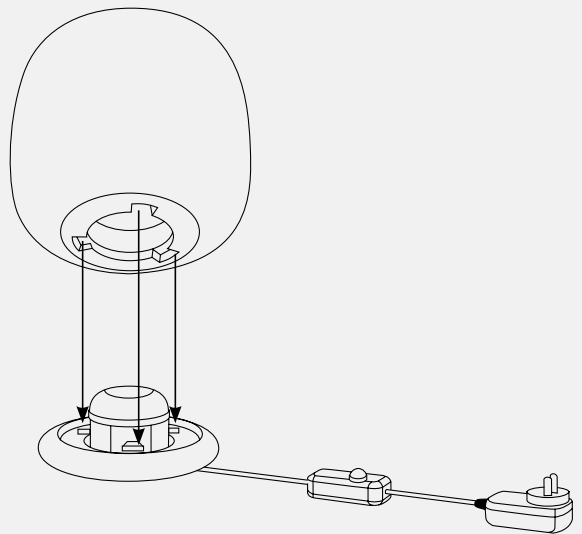

### Step 2

Put the glass lampshade onto the marble base;  
Rotate the glass lampshade to clamp the blades into the gaps.

